

XGS-PON OLT N1/N2/C+ SFP+

Optical Transceiver

Product Features

- Complies with ITU-T XGS-PON G.9807.1
- Support XGSPON or XGPON 20km application
- Single fiber bi-directional data links
- 1577nm 9.95328Gbps continuous-mode transmitter with EML laser, 1270nm 9.95328Gbps/2.488Gbps burst-mode receiver using APD-TIA.
- 2-wire interface for integrated digital diagnostic monitoring
- Digital receiving signal strength indication (RSSI)
- SFP+ MSA package with SC/UPC receptacle optical interface
- +3.3V power supply
- Operating case temperature: 0~70°C
- RoHS compliance, and Class 1 laser safety

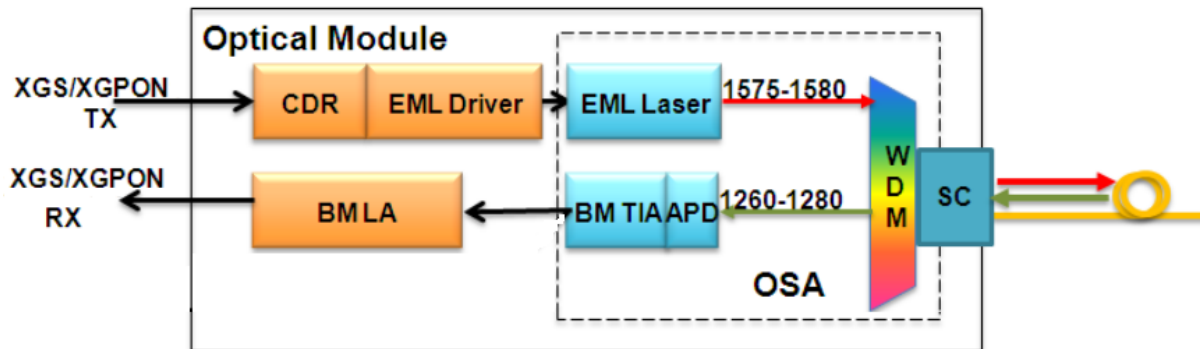

Operating Condition

Parameter	Unit	Min.	Typical	Max.
Storage Temperature	°C	-40		85
Operating Case Temp	°C	0		70
Operating Relative Humidity	%	5		85
Power Supply Voltage(3.3V)	V	3.135	3.3	3.465
Supply Current(3.3V)	mA		650	-
Bit Rate for Tx 1577nm	Gbps	9.95328		
Bit Rate for Rx 1270nm	Gbps	9.95328/2.488Gbps/		

Characteristics

All performance is specified at whole working temperature and conditions

Parameter	Unit	Min.	Typical	Max.
1577nm 9.95328Gbps Transmitter				
TX Central Wavelength	nm	1575	1577	1580
Spectral Width (-20dB)	nm			1
SMSR	dB	30		
Mean Launched Power-N1	dBm	2		5
Mean Launched Power-N2	dBm	4		7
Mean Launched Power-C+	dBm	6		9
Mean Launched Power (TX Off)	dBm			-39
Extinction Ratio	dB	8.2		
Optical Return Loss Tolerance	dB	-15		
Transmitter and dispersion Penalty	dB			1
Transmitter Mask (PRBS2 ³¹ -1@9.95328G)	Compliant With ITU-T G.9807.1			
1270nm 9.95328Gbps/2.488Gbps Receiver				
Receive Wavelength	nm	1260	1270	1280
Sensitivity -N1 (PRBS2 ³¹ -1@9.95328G, ER=6dB, BER<10 ⁻³)	dBm			-26
Sensitivity -N1 (PRBS2 ³¹ -1@2.488G, ER=8.2dB, BER<10 ⁻⁴)	dBm			-27.5
Sensitivity -N2 (PRBS2 ³¹ -1@9.95328G, ER=6dB, BER<10 ⁻³)	dBm			-28.5
Sensitivity -N2 (PRBS2 ³¹ -1@2.488G, ER=8.2dB, BER<10 ⁻⁴)	dBm			-29.5
Sensitivity -C+ (PRBS2 ³¹ -1@9.95328G, ER=6dB, BER<10 ⁻³)	dBm			-30
Overload-N1	dBm	-4.5		
Overload-N2	dBm	-6.5		
Overload-C+	dBm	-9		
SD Assert Level	dBm			-30.5
SD De-assert Level	dBm	-45		
SD Hysteresis	dB	0.5		6
Electrical Interface Characteristics				
Data Input Swing Differential/TX	mV	120		820
Data Output Swing Differential/RX	mV	340		850
Data Differential Impedance	Ω	90	100	110
LVTTL Output High	V	2.4		V _{cc}
LVTTL Output Low	V	0		0.4
LVTTL Input High	V	2.0		V _{cc} +0.3
LVTTL Input Low	V	0		0.8

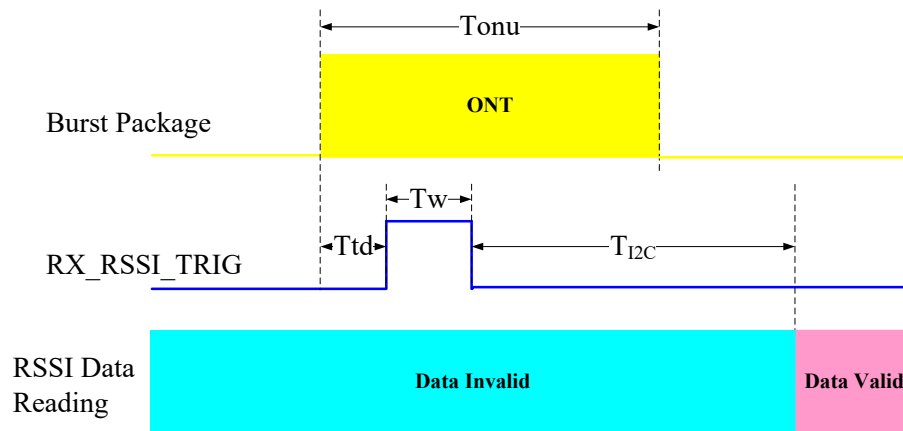
Timing Sequence for RSSI

Parameter	Unit	Min.	Typical	Max.
RSSI Timing Characteristics				
ONU Package Length (T_{ont})	ns	500	-	-
RSSI Trigger Delay (T_{td})	ns	0	300	3000
RSSI Trigger Pulse Width (T_w)	ns	500	-	-
Internal I ² C Delay (T_p)	us			500
RSSI Power Range (P_{mon})	dBm	-30		-7
RSSI Monitoring Error	dB	+/-3		

PIN Definition

Pin No.	Symbol	Level / Logic	Description
1	GND		Module Ground
2	Tx_FAULT	LVTTL-O	TX Fault Alarm, TX Fault State: High; TX Normal State: Low
3	Tx_DIS	LVTTL-I	Active high to turn off transmitter laser output.
4	SDA	LVTTL-I/O	2-Wire Serial Interface Data Line
5	SCL	LVTTL-I	2-Wire Serial Interface Clock
6	Mod_Abs	LVTTL -O	Module Absent indicate pin. Grounded inside the module.
7	RX_RESET	LVTTL-I	RX burst reset
8	Rx_SD	LVTTL-O	Receiver Signal Detected.
9	RSSITrig	LVTTL-I	Active high to trigger the RSSI sampling.
10	GND		Module Ground.
11	GND		Module Ground.
12	RD-	CML-O	Receiver Inverted Data Output, DC-coupled
13	RD+	CML-O	Receiver Non-Inverted Data Output, DC-coupled
14	GND		Module Ground.
15	V _{CC3_RX}		+3.3V Rx Power Supply
16	V _{CC3_TX}		+3.3V Tx Power Supply
17	GND		Module Ground.
18	TD+	CML-I	Transmitter Non-Inverted Data Input, AC-coupled.
19	TD-	CML-I	Transmitter Inverted Data Input, AC-coupled.
20	GND		Module Ground.

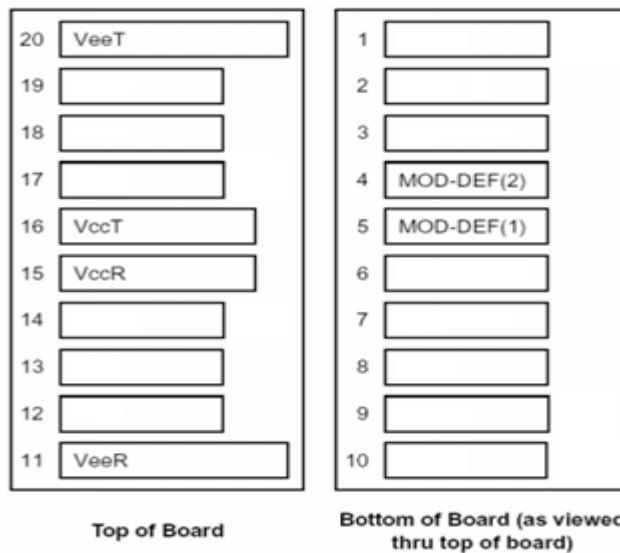

Typical Interface Circuit

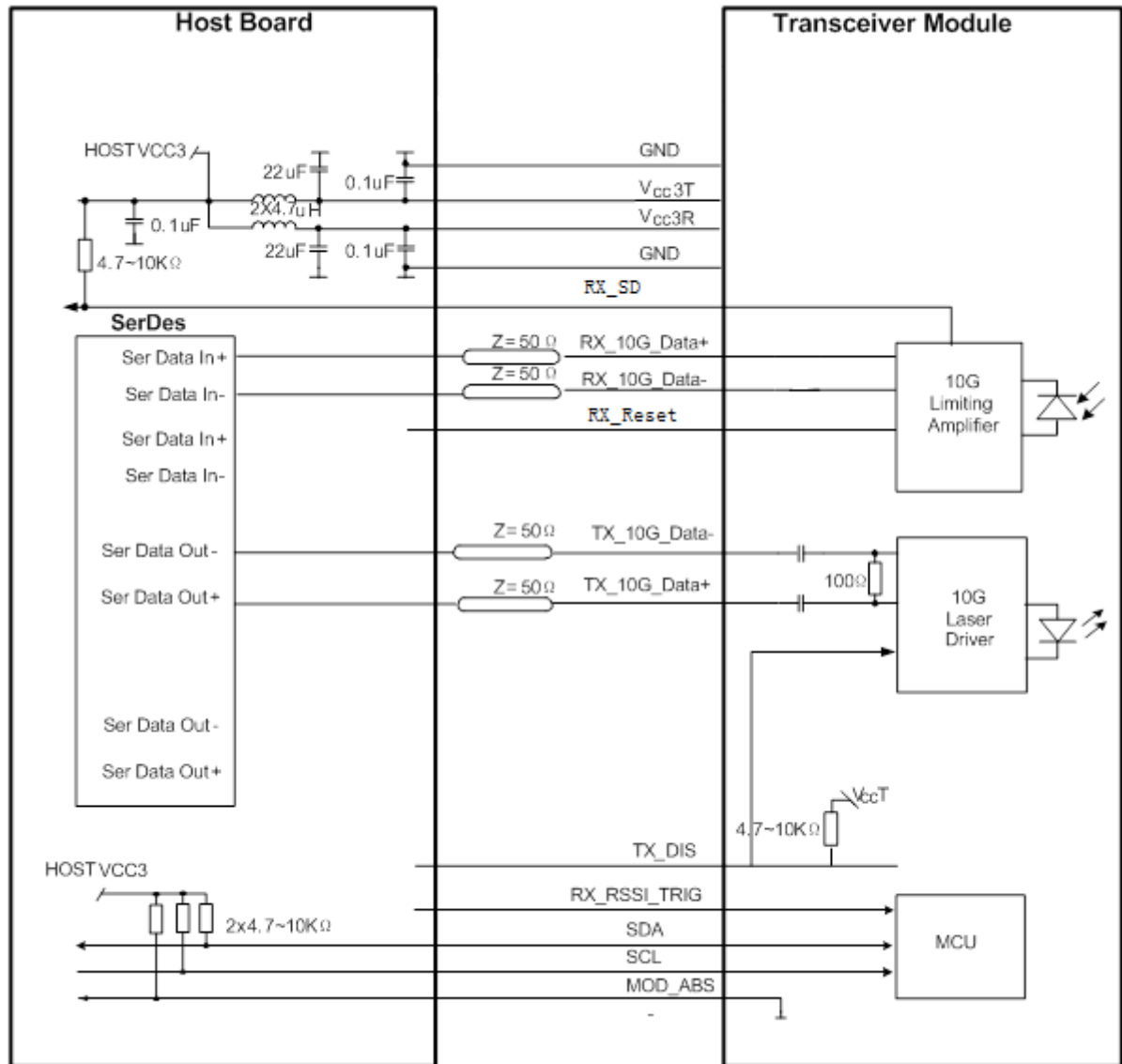

Mechanical Diagram

For detail mechanical information, please refer to the related document of SFF-8432

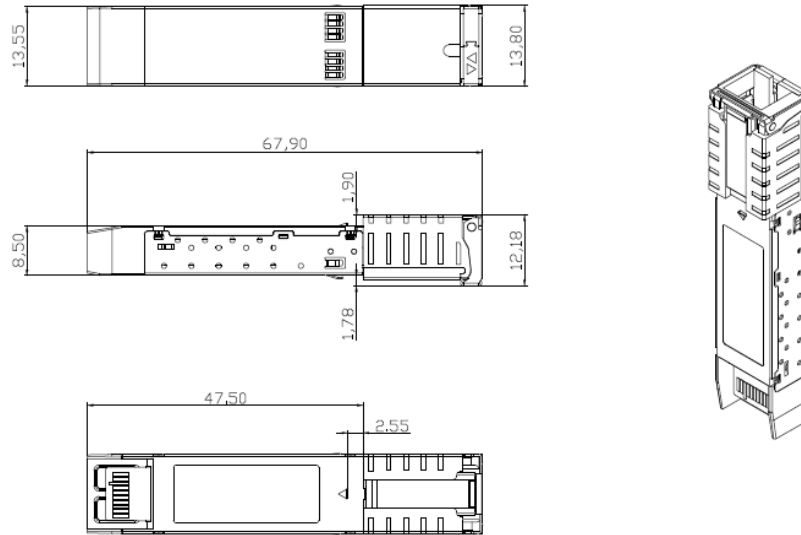

EEPROM Memory Map

The digital diagnostic memory map specific data field define as following. For detail EEPROM information, please refer to the related document of SFF 8472 Rev 12.0.

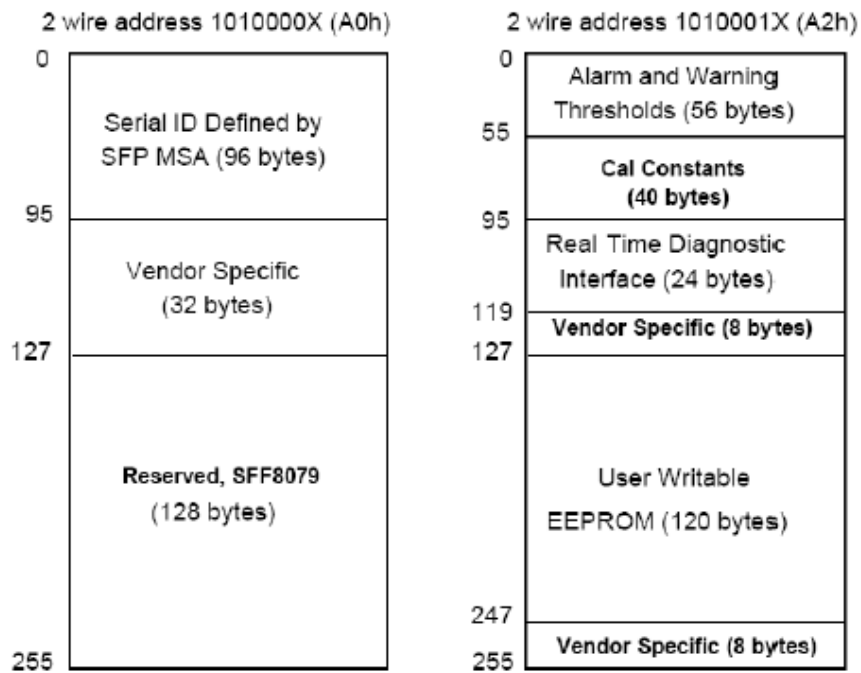

ESD

The SFP+ module and host SFI contacts (High Speed Contacts) shall withstand 1kV electrostatic discharge based on Human Body Model and all host contacts with exception of the SFI contacts (High Speed Contacts) shall withstand 2kV electrostatic discharge based on Human Body Model. The SFP+ module shall meet ESD requirements given in EN61000-4-2, criterion B test specification such that units are subjected to 15kV air discharges during operation and 8kV direct contact discharges to the case per section 2.9 in SFF-8431 REV4.1. However, normal ESD precautions are still required during the handling of this module. This transceiver is shipped in ESD protective packaging. It should be removed from the packaging and handled only in an ESD protected environment.

Laser Safety

This is a Class 1 Laser Product according to IEC 60825-1:2007. This product complies with 21 CFR 1040.10 and 1040.11 except for deviations pursuant to Laser Notice No. 50, dated (June 24, 2007).

Ordering Information

Ordering P/Ns	Description
D272RR-SSCC	XGSPON OLT, N1,TX 1577nm 9.95328Gbps, RX 1270nm 9.95328/2.488Gbps/1.25Gbps, SFP+ form-factor, BIDI SC/UPC Receptacle, 0~70°C Commercial Temperature
D372RR-SSCC	XGSPON OLT, N2,TX 1577nm 9.95328Gbps, RX 1270nm 9.95328/2.488Gbps, SFP+ form-factor, BIDI SC/UPC Receptacle, 0~70°C Commercial Temperature
D472RR-SSCC	XGSPON OLT, C+,TX 1577nm 9.95328Gbps, RX 1270nm 9.95328, SFP+ form-factor, BIDI SC/UPC Receptacle, 0~70°C Commercial Temperature

Contact Us**International Sales**

Email: Sales@broadex-tech.co.uk

Tel: +44-1506-426021

Mobile: +44-7968-854124

China Sales

Tel: +86-573-82585881

Email: Sales@broadex-tech.com

Copyright © 2020 Broadex Technologies. All rights reserved